

Count on a higher yield with the
FALCON conti



Count on a higher yield with the FALCON conti precision portion cutting machine



The FALCON conti portion cutting machine can be loaded continually via a conveyor belt and achieves first-class weight results even with boned products such as chops. The precision it offers means that you can expect a continuously high output.

It goes without saying that the same also applies if you are seeking to use the FALCON conti to cut your products to a certain slice thickness without any kind of weight specification.

Technical data:

Max. cuts per minute (Theoretical maximum value)	550
Cross-section of product W x H (mm/inch)	260 x 155; 220 x 155 10 1/5" x 6 1/10"; 8 3/5" x 6 1/10"
Max. infeed length (mm/inch)	1,000; 39 3/10"
Housing dimensions (mm/inch)	
Length without check weigher/ with check weigher and sorting station/ with check weigher and two sorting stations	4,525/5,662/6,475 178 1/10"; 222 9/10"; 254 9/10"
Width/Height (mm/inch)	1,377/1,856; 54 1/5"; 73 1/10"
Connected load (kW)	8.6 without check weigher; 9.6 with check weigher
Applications	Up to -4 °C/24.8 °F
Weight machine (50 Hz/60 Hz) (kg/lb)	1,036; 2,284
Weight check weigher with sorting station, 2 pushers (kg/lb)	510; 1,124
Product specific accessories (e.g. for fresh meat)	on request



Maximum precision with continuous loading



Loading takes place continuously via a conveyor belt. Products are automatically transported to the cutting area.

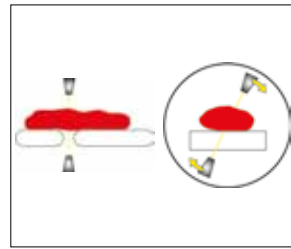

The "heart" of the machine is the scanner technology. The scanners carry out a 360° survey of the cutting material, conducting 2,000 measurements a second.



The product fixing system ensures product stability, an essential prerequisite for first-class cutting results.



The FALCON conti is capable of handling cooked products as well as heavily smoked products e.g. Black Forest Ham. It can also slice cheese.



The intelligent gripper recognises which parts of the cutting material are harder (i.e. contain bones) and simply rests gently on these areas. The other hooks hold the meat safely in place.



The grouping unit enables the packaging of boneless products and the discharge of individual slices, e.g. when there is a deviation from the target weight. The dynamic portion separation guarantees the clean and precise depositing of the slices on the grouping belt.

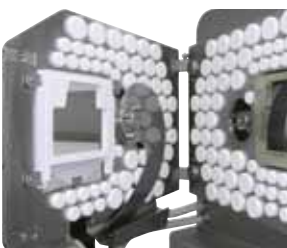

The patented sickle blade is firmly secured between two stainless steel plates. This so-called sandwich guidance system prevents wedge cuts, resulting in clean cuts and increased output.



Any product movement can exert a negative impact on the quality of cut. For this reason, the rib stabiliser provides boned goods with extra hold and thus minimises the cutting pressure on the product.

Extend the shelf life of your products

The fact that the machine can be used on automated production lines means that an uninterrupted chilled and hygienic line is created. Due to less touching of the product, the shelf life of your self-service products will be longer.



The FALCON conti is the ideal solution for those who require a continuous loading and who are seeking to cut products to a precise thickness without weight specification.



Products up to 1,000 mm / 39 ³/₁₀" in length can be processed.



The tolerance area for deviations from the target weight is set by the operator. Slices which are not of the correct weight are automatically sorted out (check weigher/pusher optional).

Your benefits at a glance:

- Continuous loading – high yield at all times – top weight results – 100 cutting programmes – can be used on automated production lines
- Ideal for cutting according to slice thickness without weight specification including residual product optimisation
- Portioning of one product in various weights with the touch of a button/calculation of the optimum slice thickness in order to achieve the target weight
- Check weigher/sorting station with pusher(s) for e.g. sorting out slices which are overweight or underweight (optional)
- Grouping unit for the packaging boneless products (optional)
- Dynamic portion separation for depositing of single portions (optional)
- Highly flexible cutting system featuring a range of optional modules such as pre-scale/dynamic portion separation for depositing of single portions for products that contain bones, deep frozen goods and very hard cutting material/grouping unit/check weigher/sorting station/automatic loading
- FALCON conti robotic: fully-automatic sorting and infeeding process using robotic technology (up to 82 picks per minute, available on request)

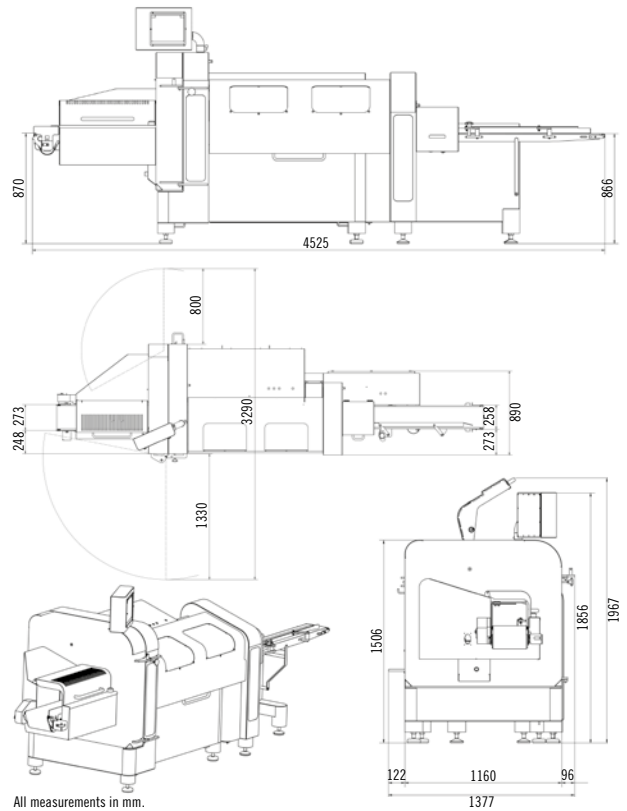

www.treif.com

HEADQUARTERS:

TREIF Maschinenbau GmbH
Südstraße 4
D-57641 Oberlahr
Tel. +49 2685 944 0
Fax +49 2685 1025
E-Mail: info@treif.com

LOCATIONS:

TREIF S.A.R.L.
22, rue des Tuileries
F-67460 Souffelweyersheim
Tel. +33 3 8818 4018
Fax +33 3 8818 4019
E-Mail: info-france@treif.com

TREIF USA Inc.
230 Long Hill Cross Road
USA-Shelton CT 06484
Tel. +1 203 929 9930
Fax +1 203 929 9949
E-Mail: treifusa@treif.com

TREIF U.K. Ltd.
4 Europa Park
Croft Way Eastways
GB-Witham Essex CM 8 2FN
Tel. +44 1376 504060
Fax +44 1376 504070
E-Mail: info@treif.co.uk

TREIF in Belgium
Villalaan 21
B-9320 Aalst
Tel. +32 53 770813
Fax +32 53 789666
E-Mail: jo.luypaert@treif.com

TREIF China
TREIF Maschinenbau GmbH
Room 212, No. 188 Zhangyang Rd.
PRC-Shanghai, 200120 China
Tel. +86 21 5879 8255
Fax +86 21 5879 8256
E-Mail: treif.china@treif.com