

Precision you can rely on:
FALCON



Precision you can rely on. FALCON – a sharp eye that pays dividends quickly



The FALCON takes an extremely precise view of the work it does. It slices both bone-in and boneless products to the desired weight irrespective of whether it is dealing with fresh meat, cooked meat or smoked goods.

The FALCON can process cutting material up to 820 mm / 32 ³/₁₀" in length and can achieve as many as 240 cuts per minute depending on the product.

Technical data:

Max. cuts per minute (Theoretical maximum value)	240
Cross-section of product W x H (mm/inch)	260 x 155; 220 x 155 / 10 ¹ / ₅ " x 6 ¹ / ₁₀ "; 8 ³ / ₅ " x 6 ¹ / ₁₀ "
Max. infeed length (mm/inch)	820; 32 ³ / ₁₀ "
Housing dimensions (mm/inch)	
Length without check weigher / with check weigher (mm/inch)	2,666 / 3,780; 104 ⁷ / ₁₀ " / 148 ⁴ / ₅ "
Width / Height (mm/inch)	1,377 / 1,859; 54 ¹ / ₂ " / 73 ¹ / ₂ "
Connecting load (kW)	7.0 without check weigher; 8.0 with check weigher
Products	Up to -4 °C; 24.8 °F
Weight machine (50 Hz/60 Hz) (kg/lb)	750 / 790; 1,654 / 1,742
Weight check weigher with pusher (kg/lb)	350; 772
Weight precision (%) (for boneless products, depending on product/consistence of product)	+/-0,5 bis +/-5
Product specific accessories (e.g. for fresh meat)	on request



A piece of productivity in every single slice

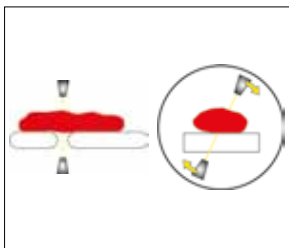

The "heart" of the machine is the scanner technology. The scanners carry out a 360° survey of the cutting material, conducting 2,000 measurements a second.



The FALCON can also slice cheese to the required weight. The broad cutting spectrum and the diverse areas of application the FALCON is able to offer means that the machine very quickly pays for itself.



The FALCON is extremely flexible and can cut everything from pork belly to soft entrecôte to pork loin frozen to a temperature of -4 °C/24.8 °F.



The patented sickle blade is firmly secured between two plates. This so-called sandwich guidance system (stainless steel plates on request) prevents wedge cuts, resulting in clean cuts and increased output.



The intelligent gripper recognises which parts of the cutting material are harder (i.e. contain bones) and simply rests gently on these areas. The other hooks hold the meat safely in place.



The FALCON is capable of handling cooked products as well as heavily smoked products e.g. Black Forest Ham.



Any product movement can exert a negative impact on the quality of cut. For this reason, the rib stabiliser provides boned goods with extra hold and thus minimises the cutting pressure on the product.



The check weigher and the sorting station are available as optional extras. The tolerance area for deviations from the target weight is set by the operator. Slices which are not of the correct weight are automatically sorted out.

Isn't it time to increase your output too?

The FALCON displays a degree of versatility which no other machine can match and can process everything from raw ham to chops to feta cheese. The precision it offers also guarantees you high output.



There is no need to squash your products by forcing them into a shape. The FALCON uses a 360° scanner instead of conventional mould technology.



It also goes without saying that the FALCON is capable of cutting products in accordance with thickness of slice.



A few simple hand grips are all that is required to prepare the FALCON for cleaning. Protective covers are supplied for sensitive components (such as scanners).

Your benefits at a glance:

- Precisely weighted resp. output enhanced cutting of boneless, bone-in, tough smoked and even slightly frozen products
- Fast amortisation due to variable use with regard to the product range and applications
- Innovative software (intuitive menu guide) with allocation of user rights over four levels as well as remote maintenance and online software update
- Compatible with all further processing machines generally available on the market
- Security of production thanks to storage of cutting parameters – 100 cutting programmes available
- Sandwich guidance system of the blade delivers clean cuts every time (stainless steel plates optional)
- 360° scanner provides a high degree of weight accuracy – product is completely scanned without being squeezed out of shape
- Unfolding mechanism for quick cleaning

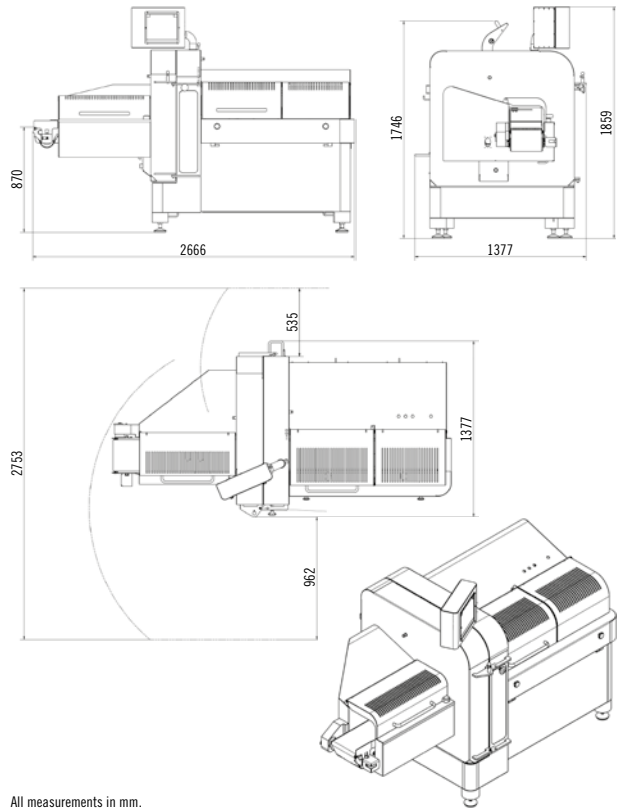

All measurements in mm.

www.treif.com

HEADQUARTERS:

TREIF Maschinenbau GmbH
Südstraße 4
D-57641 Oberlahr
Tel. +49 2685 944 0
Fax +49 2685 1025
E-Mail: info@treif.com

LOCATIONS:

TREIF S.A.R.L.
22, rue des Tuileries
F-67460 Souffelweyersheim
Tel. +33 3 8818 4018
Fax +33 3 8818 4019
E-Mail: info-france@treif.com

TREIF USA Inc.
230 Long Hill Cross Road
USA-Shelton CT 06484
Tel. +1 203 929 9930
Fax +1 203 929 9949
E-Mail: treifusa@treif.com

TREIF U.K. Ltd.
4 Europa Park
Croft Way Eastways
GB-Witham Essex CM 8 2FN
Tel. +44 1376 504060
Fax +44 1376 504070
E-Mail: info@treif.co.uk

TREIF in Belgium
Villalaan 21
B-9320 Aalst
Tel. +32 53 770813
Fax +32 53 789666
E-Mail: jo.luybaert@treif.com

TREIF China
TREIF Maschinenbau GmbH
Room 212, No. 188 Zhangyang Rd.
PRC-Shanghai, 200120 China
Tel. +86 21 5879 8255
Fax +86 21 5879 8256
E-Mail: treif.china@treif.com