

One machine that cuts dices and chops – HUSKY dual purpose cutting machine

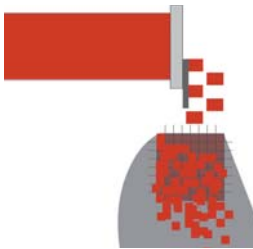

The AVS (Automatic Pre-pressing System) produces optimal exact shapes of the dices or strips right from the start.



Paprika dices

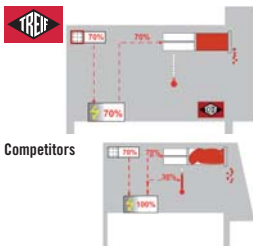

Because of the patented DHS (Dynamic Hydraulic System) the storage life of the cut goods is prolonged (less heat development of the machine, less bacteria growth).



Poultry strips



As a portion cutting machine HUSKY processes products with and without bones. The loading chamber provides space for entire products.



Goulash dices

Do you want to dice boiled ham and offer your customers juicy pork and beef goulash as well as thinly sliced meat? Do you want to cut chops, cured ham and schnitzel in clean slices and grate cheese or red cabbage?



The products are pressed into the chamber with the tilting compression lid so that it is always used to its fullest capacity.



Cutlets

The fact that machines are capable of doing this is not new but the surprise is that one single machine can handle all these tasks. HUSKY is the only dual cutting machine on the market that is able to handle what normally can only be done with two machines.

HUSKY cuts for 2

Converting the HUSKY from a powerful portioning machine to a high-throughput dicer takes less than 2 minutes.

Technical data:	HUSKY for dicing	HUSKY for portioning
Max. output t/h (depends on the product and application)	2,0; 4,410 lbs	2,0; 4,410 lbs
Cut-off length (mm/inch)	1-50; $\frac{4}{100}$ " - 2"	1-50; $\frac{4}{100}$ " - 2"
Max. cuts/minute	-	175
Max. cut-off blade speed/minute	300	-
Gridset / cross-section of product (mm/inch)	96 x 96; $3\frac{4}{5}$ " x $3\frac{4}{5}$ "	180 x 180; 7" x 7"
Max. infeed length (mm/inch)	550; $21\frac{1}{10}$ "	600; $23\frac{2}{5}$ "
Housing dimensions (mm/inch)		
Length / Width / Height (mm)	2.265 / 914 / 1.200; $89\frac{1}{5}$ " / $36\frac{1}{8}$ " / $47\frac{1}{5}$ "	2.265 / 914 / 1.200; $89\frac{1}{5}$ " / $36\frac{1}{8}$ " / $47\frac{1}{5}$ "
Connecting load (kW)	2,0	2,0
Gridsets (mm/inch)	4/5/6/8/10/12/14/16/20/24/ - 32/48/96; $\frac{1}{5}$ " ; $\frac{3}{10}$ " ; $\frac{2}{5}$ " ; $\frac{1}{2}$ " ; $\frac{3}{5}$ " ; $\frac{4}{5}$ " ; 1" ; $1\frac{3}{10}$ " ; 2" ; $3\frac{4}{5}$ "	-
Weight (kg/lb)	approx. 389	approx. 389
Product specific accessoires	on request	on request

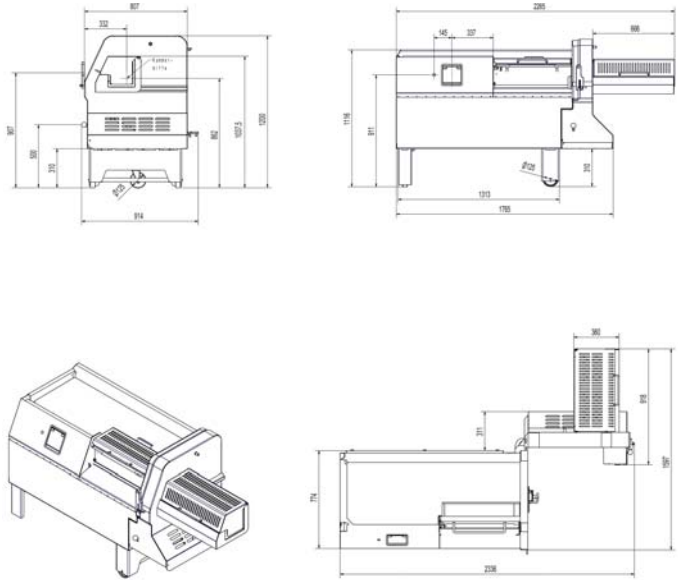

The double blade provides more output. Different blades and gridset sizes expand the cutting scope.



The blade rotation can be optimally adjusted to your product, both when portioning or dicing.



Special accessories are available (as option). The grating disk is used, for example, to cut potatoes into thin slices or to grate cheese.

Your benefits at a glance:

- Enormous flexibility: conversion in less than 2 minutes
- Saves on costs, space and time due to the dual purpose use of a single machine
- Same functionality and equipment as all TREIF dicers and all TREIF portioning machines

HUSKY - Dicing machine

- Best cutting quality thanks to the high-tech systems AVS and DHS
- Gridset change without tools with "Click&Go" gridset
- Highest possible product yield

HUSKY - Portioning machine

- Precision even when cutting products with bones thanks to precision sickle blade (TREIF patent)
- Saving time with automatic start-up device
- Maximum productivity due to residual product optimisation

www.treif.com

HEADQUARTERS:

TREIF Maschinenbau GmbH
Südstraße 4
D-57641 Oberlahr
Tel. +49 2685 944 0
Fax +49 2685 1025
E-Mail: info@treif.com

LOCATIONS:

TREIF S.A.R.L.
22, rue des Tuileries
F-67460 Souffelweyersheim
Tel. +33 3 8818 4018
Fax +33 3 8818 4019
E-Mail: info-france@treif.com

TREIF USA Inc.
230 Long Hill Cross Road
USA-Shelton CT 06484
Tel. +1 203 929 9930
Fax +1 203 929 9949
E-Mail: treifusa@treif.com

TREIF U.K. Ltd.
4 Europa Park
Croft Way Eastways
GB-Witham Essex CM 8 2FN
Tel. +44 1376 504060
Fax +44 1376 504070
E-Mail: info@treif.co.uk

TREIF in Belgium
Villalaan 21
B-9320 Aalst
Tel. +32 53 770813
Fax +32 53 789666
E-Mail: jo.luypaert@treif.com

TREIF China
TREIF Maschinenbau GmbH
Room 212, No. 188 Zhangyang Rd.
PRC-Shanghai, 200120 China
Tel. +86 21 5879 8255
Fax +86 21 5879 8256
E-Mail: treif.china@treif.com