

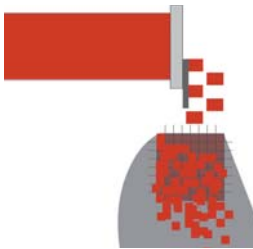

## Dicing, cutting stripes, grating – with TWISTER



The AVS (automatic pre-compression system) facilitates an optimal dimensional accuracy of the dices and stripes right from the beginning.



Goulash cubes are of course part of the cutting repertoire of the TWISTER.

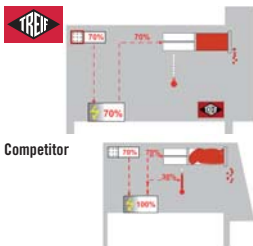

As a result of the patented DHS (Dynamic Hydraulic System), the cut products stay fresh longer (the machine generates less heat, so there is less of a chance for bacteria to form).



Cooked products, like poultry in this example, can also be cut with ease.



The separating slide operates in a curving motion. This enables user-friendly, one-hand operation.



TWISTER is very versatile. The different cutting parameters can be saved (up to 50 cutting programs).

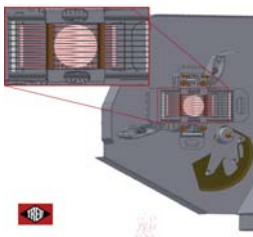

Excellent cutting results thanks to counter-rotation grid. This achieves highest cut geometry which leads to excellent cutting results, especially with delicate products such as cooked meat.



The dice and stripe cutting machine can process up to 3.5 t in one hour (max. output). The blade revolution speed can be individually set.

In one hour the dice and stripe cutting machine achieves a max. output of up to 3,500 kg, even during constant operation.

It can handle highest stresses, even with respect to the loading. TWISTER can be optionally fitted with a convenient and reliable lift for E-boxes. For the operator that means: At last, no more straining bending and heavy, strenuous lifting.

## Gentle cut

With the help of the counter-rotation grid (optional), delicate products such as cooked meat or poultry are cut gently, thus achieving excellent cutting results.

### Technical data:

Max. output t/h (depends on the product and application)	3,5; 7,716 lbs
Max. cut-off length (mm/inch)	1–50; 4/100"–2"
Max. cut-off blade speed/min.	300/400 (TWISTER G)
Housing dimensions (mm/inch)	
Length/Width/Height with lift and outlet conveyor (mm/inch)	1,900/1,800/1,280; 74 4/5" / 71" / 50 2/5"
Connecting load (kW)	4.5 (TWISTER G: 6.0)
Gridsets (mm/inch)	4/5/6/8/10/12/15/17/20/24/30/40/60/120; 1/5" ; 3/10" ; 2/5" ; 1/2" ; 3/5" ; 7/10" ; 5/4" ; 1" ; 1 1/5" ; 1 3/5" ; 4 7/10"
Weight with lift & outlet conveyor (kg/lb)	approx. 670; 1,477
Product specific accessories	on request

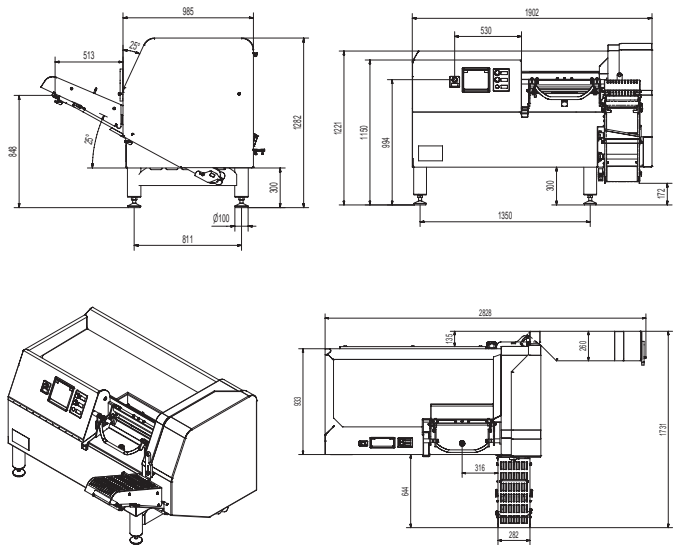

Cleaning channel for a better flow of liquids, e.g. meat juice, rinsing water.



The cheese grid is a necessity for precise cheese dices that are true to shape.



TWISTER basic can also be fitted with a scale.

### Your benefits at a glance:

- Semi-automatic loading
- Flexibility and top performance thanks to continuous and intermittent cutting options and the ability to individually set the blade speed
- Optimum product compression as a result of the automatic pre-compression system (AVS)
- Ergonomic, one-hand operating system for closing the loading chamber; chamber size: 550 x 120 x 120 mm / 21 7/10" x 4 7/10" x 4 7/10" (length x width x height)
- Patented counter-rotation grid for delicate products (optional)
- Hygiene cylinder guarantees that uncut products are not contaminated with hydraulic oil (optional)

[www.treif.com](http://www.treif.com)

#### HEADQUARTERS:

**TREIF Maschinenbau GmbH**  
Südstraße 4  
D-57641 Oberlahr  
Tel. +49 2685 944 0  
Fax +49 2685 1025  
E-Mail: [info@treif.com](mailto:info@treif.com)

#### LOCATIONS:

**TREIF S.A.R.L.**  
22, rue des Tuileries  
F-67460 Souffelweyersheim  
Tel. +33 3 8818 4018  
Fax +33 3 8818 4019  
E-Mail: [info-france@treif.com](mailto:info-france@treif.com)

**TREIF USA Inc.**  
230 Long Hill Cross Road  
USA-Shelton CT 06484  
Tel. +1 203 929 9930  
Fax +1 203 929 9949  
E-Mail: [treifusa@treif.com](mailto:treifusa@treif.com)

**TREIF U.K. Ltd.**  
4 Europa Park  
Croft Way Eastways  
GB-Witham Essex CM 8 2FN  
Tel. +44 1376 504060  
Fax +44 1376 504070  
E-Mail: [info@treif.co.uk](mailto:info@treif.co.uk)

**TREIF in Belgium**  
Villalaan 21  
B-9320 Aalst  
Tel. +32 53 770813  
Fax +32 53 789666  
E-Mail: [jo.luybaert@treif.com](mailto:jo.luybaert@treif.com)

**TREIF China**  
TREIF Maschinenbau GmbH  
Room 212, No. 188 Zhangyang Rd.  
PRC-Shanghai, 200120 China  
Tel. +86 21 5879 8255  
Fax +86 21 5879 8256  
E-Mail: [treif.china@treif.com](mailto:treif.china@treif.com)