

DIVIDER orbital circular knife slicer: for the cost-effective entry into the slicer business



Circular knife technology comes as a standard on DIVIDER orbital.



The patented vacuum gripper (optional) securely holds soft products such as boiled sausage, thereby ensuring that the residual piece is as small as possible.

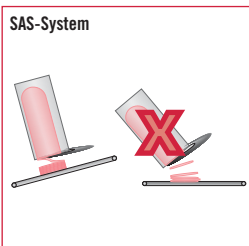

SAS-System

Optimum product delivery as a result of the only SAS process in the world (TREIF patent).



A belt extension is available as an option.



DIVIDER orbital always achieves an optimum product presentation and places the cut products in a precise fan pattern.



DIVIDER orbital places the cut products in a precise fan pattern.



It can accommodate slice lengths between 0.5 mm and 25 mm and it can produce up to 1,200 slices per minute.



It can produce up to 1,200 slices per minute.



DIVIDER orbital is the optimum solution for anyone looking for a compact, flexible slicer. For example, those who want take that first step toward professional slicing, but don't want to forego performance in the process. With its circular knife, the slicer offers the ability to slice a wide variety of products without the need to make any changes to the machine. The machine achieves optimum product presentation with the only SAS process in the world, combined with the circular knife technology of one of the newest TREIF patents.

Circular knife as a standard feature

DIVIDER orbital is equipped with a circular knife. This makes TREIF the only manufacturer of slicers that offers both circular and sickle knife technology within this class of slicers.

Technical data:

Max. cut-off length (mm/inch)	0,5–25; 1/50"–1"
Max. cut-off length (mm/inch)	1,200
Max. infeed length (mm/inch)	850
Cross section of product w x h (mm/inch)	280 x 135; 11" x 5 3/10"
Housing dimensions (mm/inch)	
Length/Width with outlet conveyor	2,558 / 981
Transport/Set-up height	1,900 / 2,200; 74 4/5" / 86 3/5"
Connecting load (kW)	4.8
Weight (kg/lb)	approx. 620; 1,367
Product specific accessoires	on request

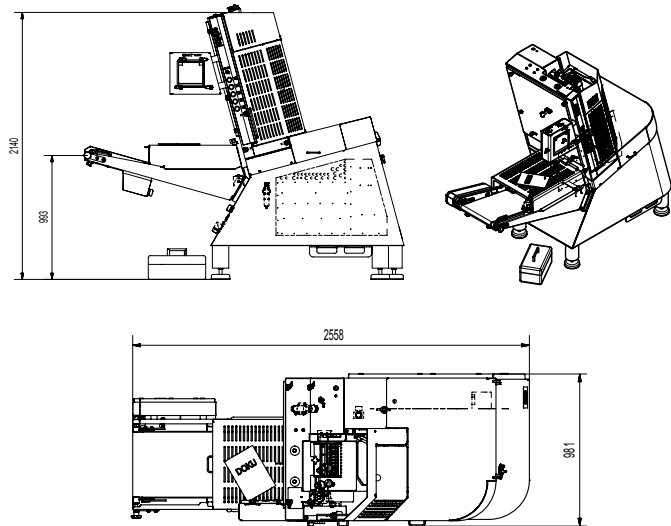

Different line solutions are possible; the solution here includes a checkweigher.



Thanks to various add-on modules, your slicer can be expanded to accommodate more sophisticated tasks.



The cutting frame can be removed manually in just a few steps.

Your benefits at a glance:

- Optimally-suited for entry into the slicer business
- Perfect delivery thanks to SAS procedure combined with circular knife technology (one of the newest TREIF patents!)
- Many products – one configuration: Change the product without changing the system
- No "snippet accumulation" as a result of blank cuts, and no „standby times“ because the slicing is always continuous
- Belt extension as connection to the packaging machine (optional)
- The knife is operated by V-ribbed belts instead of an elaborate gear drive: In the event of a defect, the belts can be changed by a trained person or regular metalworker

www.treif.com

HEADQUARTERS:

TREIF Maschinenbau GmbH
Südstraße 4
D-57641 Oberlahr
Tel. +49 2685 944 0
Fax +49 2685 1025
E-Mail: info@treif.com

LOCATIONS:

TREIF S.A.R.L.
22, rue des Tuileries
F-67460 Souffelweyersheim
Tel. +33 3 8818 4018
Fax +33 3 8818 4019
E-Mail: info-france@treif.com

TREIF USA Inc.
230 Long Hill Cross Road
USA-Shelton CT 06484
Tel. +1 203 929 9930
Fax +1 203 929 9949
E-Mail: treifusa@treif.com

TREIF U.K. Ltd.
4 Europa Park
Croft Way Eastways
GB-Witham Essex CM 8 2FN
Tel. +44 1376 504060
Fax +44 1376 504070
E-Mail: info@treif.co.uk

TREIF in Belgium
Villalaan 21
B-9320 Aalst
Tel. +32 53 770813
Fax +32 53 789666
E-Mail: jo.luypaert@treif.com

TREIF China
TREIF Maschinenbau GmbH
Room 212, No. 188 Zhangyang Rd.
PRC-Shanghai, 200120 China
Tel. +86 21 5879 8255
Fax +86 21 5879 8256
E-Mail: treif.china@treif.com