

Soon knows your bacon products better than you do: LION bacon



The horizontal chamber enables the slices to fall flat onto the conveyor belt.



The gripper hook makes it possible to hold products that are up to 270 mm/ 10³/₅".



The blade operates at a speed of up to 300 revolutions/minute.

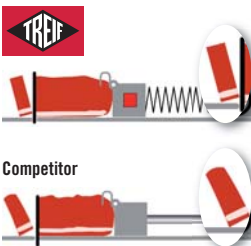

The dynamic feeding system (a standard feature) guarantees uniform slice thickness and a precise cross-section.



LION bacon slices bacon of up to -17°C/-1.4°F (depending on product and application).



This machine is a perfect alternative to a high-capacity bacon slicer.



The slices can be either shingled continuously or arranged in shingled groups of e.g. ten slices.



The machine is designed so that the products can also be stacked on top of each other and sliced.

A portion cutting machine that is named after what it is best suited for: the LION bacon.

Whether frozen, raw, cooked or smoked, with rind or without – this machine sets the bar when it comes to slicing bacon (down to -17 °C/-1.4 °F depending on the product). Thanks to the fact that it was designed specifically for bacon, even two stacked products can be loaded into the spacious chamber and still be sliced with precision.

Two models of LION bacon

LION bacon is available in the FB and EB models. The LION EB bacon model comes with an electronic control, which for example helps to keep the residual piece as small as possible.

Technical data:	LION bacon FB	LION bacon EB
Max. cut-off length (mm/inch)	0,5–70; 1/50"–2 4/5"	0,5–250; 1/50"–9 4/5"
Max. cuts per minute	300	300
Cross-section of product w x h (mm/inch)	270 x 108; 10 3/5" x 4 3/10"	270 x 108; 10 3/5" x 4 3/10"
Max. infeed length (mm/inch)	700; 27 3/5"	700; 27 3/5"
Housing dimensions (mm/inch)		
Length/Width/Height (mm/inch)	2,690/1,150/1,550; 106"/45 1/2"/61"	2,690/1,150/1,550; 106"/45 1/2"/61"
Connecting load (kW)	3.3	3.4
Products	Up to -17 °C/-1.4 °F	Up to -17 °C/-1.4 °F
Weight (kg/lb)	409; 902	409; 902
Product specific accessoires	on request	on request

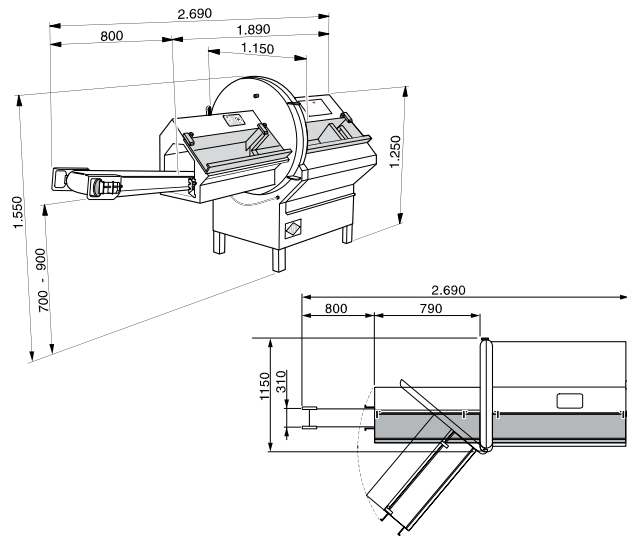

LION bacon gripper hook.



LION EB bacon can separate the uncut product into several sections so that all slices have approximately the same weight.

Your benefits at a glance:

- Visually attractive fanning of the bacon (smoked, salted pork belly) as an alternative to a high-capacity bacon slicer
- Consistent fanning and grouping (EB)
- Available with conveyor belt
- Product loading chute is fastened to the respective chamber
- Product holder is optimally suited for bacon / pork belly applications (thin and wide)
- The height of the discharge belt is aligned to the level of the cutting chamber
- Back-feed path limitation (as a standard feature)

www.treif.com

HEADQUARTERS:

TREIF Maschinenbau GmbH
Südstraße 4
D-57641 Oberlahr
Tel. +49 2685 944 0
Fax +49 2685 1025
E-Mail: info@treif.com

LOCATIONS:

TREIF S.A.R.L.
22, rue des Tuileries
F-67460 Souffelweyersheim
Tel. +33 3 8818 4018
Fax +33 3 8818 4019
E-Mail: info-france@treif.com

TREIF USA Inc.
230 Long Hill Cross Road
USA-Shelton CT 06484
Tel. +1 203 929 9930
Fax +1 203 929 9949
E-Mail: treifusa@treif.com

TREIF U.K. Ltd.
4 Europa Park
Croft Way Eastways
GB-Witham Essex CM 8 2FN
Tel. +44 1376 504060
Fax +44 1376 504070
E-Mail: info@treif.co.uk

TREIF in Belgium
Villalaan 21
B-9320 Aalst
Tel. +32 53 770813
Fax +32 53 789666
E-Mail: jo.luypaert@treif.com

TREIF China
TREIF Maschinenbau GmbH
Room 212, No. 188 Zhangyang Rd.
PRC-Shanghai, 200120 China
Tel. +86 21 5879 8255
Fax +86 21 5879 8256
E-Mail: treif.china@treif.com