

Your main gain with PUMA: Time and maximum yield



Precise cross-section as a result of the dynamic feeding system (DVS, TREIF patent).

Competitor



Performance and precision are the hallmarks of PUMA.



The intelligent product feed holder can differentiate between meat and bone simply by gripping the product.



The machine slices products at temperatures as cold as $-4\text{ }^{\circ}\text{C}/24.8\text{ }^{\circ}\text{F}$.



PUMA 700 EB



A look in the cutter box shows a thin knife for a precise cut.



Depending on the model, it can accommodate products that measure up to 700 or 1,100 mm in length.

When performance and precision align, PUMA certainly makes the cut – even at speeds of up to 400 cuts per minute (with the double knife).



Dimple plate: An air cushion forms between the dimples on which the product is guided to the knife.



Regardless of whether it is steak, schnitzel or cheese, PUMA is extraordinarily flexible.

This is true for cutlets, steaks, schnitzel, pork belly, bacon or German meatloaf, or whether it's fresh, chilled or frozen down to $-4\text{ }^{\circ}\text{C}/24.8\text{ }^{\circ}\text{F}$.

Since the knife is connected directly to the drive motor, nearly 100 % of the power from the motor can be harnessed during slicing.



Versatility of the PUMA

PUMA can slice bone-in or boneless products such as bacon, pork belly, pork blade steaks, cutlets, beef steaks, roulades or cheese products.

Technical data:	PUMA FB	PUMA E	PUMA EB
Max. cut-off length (mm/inch)	0,5–70; 1/50"–2 4/5"	0,5–250; 1/50"–9 4/5"	0,5–250; 1/50"–9 4/5"
Cuts per minute (double blade)	400	400	400
Cross-section of product w x h (mm/inch)	220 x 240; 8 3/5" x 9 1/2"	220 x 240; 8 3/5" x 9 1/2"	220 x 240; 8 3/5" x 9 1/2"
Max. infeed length (mm/inch)	700/1,100; 27 3/5" / 43 3/10"	700/1,100; 27 3/5" / 43 3/10"	700/1,100; 27 3/5" / 43 3/10"
Housing dimensions (mm/inch)			
Length/Width/Height (mm/inch)	2,750/900/1,450; 108"/35 1/5"/57"	2,850/900/1,450; 112 1/2"/35 1/5"/57"	3,270/900/1,450; 128 7/10"/35 1/5"/57"
Connecting load (kW)	3,4	3,3	3,4
Products	Up to -4 °C/24.8 °F	Up to -4 °C/24.8 °F	Up to -4 °C/24.8 °F
Weight (kg/lb)	305; 325	285; 305	305; 325
Product specific accessoires	on request	on request	on request

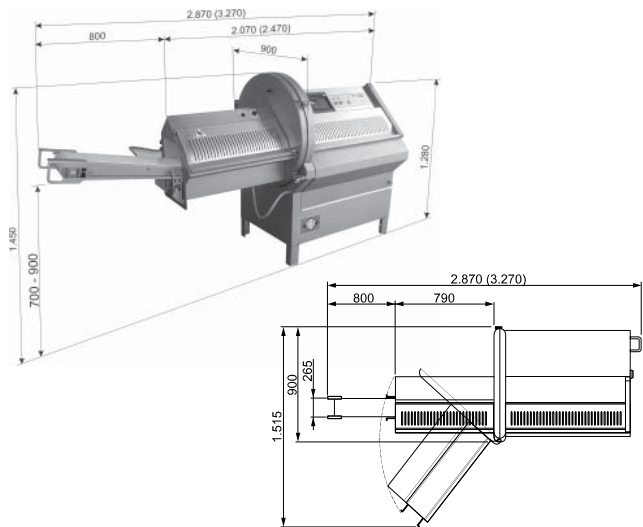

Optimal integration in the production process through package formation.

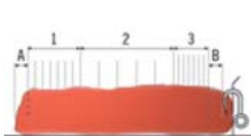

PUMA E/EB offers the capability to divide the product into several sections. Thus, all slices have approximately the same weight.



The pneumatic product feed holder automatically expels the residual piece after slicing (optional).

Your benefits at a glance:

- High-performance and precision even with bone-in products
- Increased advantage as a result of the precision sickle knife and intelligent product feed holder
- Optimum exploitation of the product as a result of residual piece optimisation and of the back-feed limitation (E/EB)
- Optimum utilisation of the product, for example by sectioning the product into slicing areas (E/EB)
- Fulfilment of the highest hygiene requirements as a result of labyrinth guidance
- HS (High-Speed) more capacity (optional)

www.treif.com

HEADQUARTERS:

TREIF Maschinenbau GmbH
Südstraße 4
D-57641 Oberlahr
Tel. +49 2685 944 0
Fax +49 2685 1025
E-Mail: info@treif.com

LOCATIONS:

TREIF S.A.R.L.
22, rue des Tuileries
F-67460 Souffelweyersheim
Tel. +33 3 8818 4018
Fax +33 3 8818 4019
E-Mail: info-france@treif.com

TREIF USA Inc.
230 Long Hill Cross Road
USA-Shelton CT 06484
Tel. +1 203 929 9930
Fax +1 203 929 9949
E-Mail: treifusa@treif.com

TREIF U.K. Ltd.
4 Europa Park
Croft Way Eastways
GB-Witham Essex CM 8 2FN
Tel. +44 1376 504060
Fax +44 1376 504070
E-Mail: info@treif.co.uk

TREIF in Belgium
Villalaan 21
B-9320 Aalst
Tel. +32 53 770813
Fax +32 53 789666
E-Mail: jo.luybaert@treif.com

TREIF China
TREIF Maschinenbau GmbH
Room 212, No. 188 Zhangyang Rd.
PRC-Shanghai, 200120 China
Tel. +86 21 5879 8255
Fax +86 21 5879 8256
E-Mail: treif.china@treif.com