

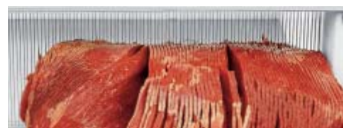

## ZEBRA: With the specialist for fresh products through "thick & thin"



Use the quick change system "push & go" to take off the 2-part grid frame.



Products with a length of up to 380 mm can be cut in the machine.



The slot gate protects from accidental grabbing of grid blade.



Slicing of cooked fine pork sausage.



All relevant machine parts are easily accessible for cleaning.



ZEBRA can cut multiple products at the same time with different slice thicknesses.



Manual settings facilitate optimal cutting results.



ZEBRA can cut slices with a thickness between 2.5 mm to 30 mm.



ZEBRA is a grid cutter machine that is especially well suited to cut fresh and soft products in thin slices.

During one process step, the slice and portion cutter can cut products in different slice thicknesses. The precise cut is achieved through the highly polished and double etched grid blade.

## ZEBRA feels at home ...

ZEBRA is particularly well-suited for food processing, industrial kitchens, super markets and commercial applications.

### Technical data:

Cuts per minute	on request
Cutting thicknesses (mm/inch)	2,5–30; 1/10"–1 1/5"
Cross-section of product w x h (mm/inch)	610 x 145; 24" x 5 7/10"
Max. Infeed length (mm/inch)	380; 15"
Housing dimensions (mm/inch)	
Length/Width/Height (mm/inch)	1,250/1,000/1,550; 49 1/2"/39 2/5"/61"
Connecting load (kW)	2.6
Products	Up to -4 °C / 24.8 °F
Weight (kg/lb)	approx. 795; 1,753
Product specific accessoires	on request

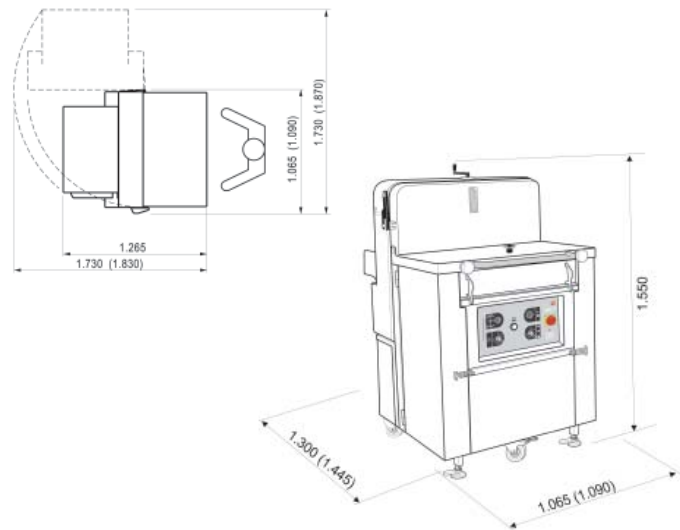

ZEBRA with belt (optional); time savings during processing and increase of productivity.



The chamber division of the portion cutter.



The product is easily pushed through the slotted back wall, clean through the grid.

### Your benefits at a glance:

- Best cutting quality for soft (boneless), fresh products
- High level of productivity through slicing of two products into different slice thicknesses in one work step
- High level of flexibility due to precise cutting of unevenly shaped products
- Time saving through "push&go" quick change gridset system (advantage during cleaning and exchange of grids)
- Very high output through simultaneous cutting of multiple products side-by-side, stacked, and back-to-back
- Grid frame with different cutting thickness (optional)
- Precise, careful, yet powerful feeding thanks to hydraulic feeding system

[www.treif.com](http://www.treif.com)

#### HEADQUARTERS:

**TREIF Maschinenbau GmbH**  
Südstraße 4  
D-57641 Oberlahr  
Tel. +49 2685 944 0  
Fax +49 2685 1025  
E-Mail: [info@treif.com](mailto:info@treif.com)

#### LOCATIONS:

**TREIF S.A.R.L.**  
22, rue des Tuileries  
F-67460 Souffelweyersheim  
Tel. +33 3 8818 4018  
Fax +33 3 8818 4019  
E-Mail: [info-france@treif.com](mailto:info-france@treif.com)

**TREIF USA Inc.**  
230 Long Hill Cross Road  
USA-Shelton CT 06484  
Tel. +1 203 929 9930  
Fax +1 203 929 9949  
E-Mail: [treifusa@treif.com](mailto:treifusa@treif.com)

**TREIF U.K. Ltd.**  
4 Europa Park  
Croft Way Eastways  
GB-Witham Essex CM 8 2FN  
Tel. +44 1376 504060  
Fax +44 1376 504070  
E-Mail: [info@treif.co.uk](mailto:info@treif.co.uk)

**TREIF in Belgium**  
Villalaan 21  
B-9320 Aalst  
Tel. +32 53 770813  
Fax +32 53 789666  
E-Mail: [jo.luypaert@treif.com](mailto:jo.luypaert@treif.com)

**TREIF China**  
TREIF Maschinenbau GmbH  
Room 212, No. 188 Zhangyang Rd.  
PRC-Shanghai, 200120 China  
Tel. +86 21 5879 8255  
Fax +86 21 5879 8256  
E-Mail: [treif.china@treif.com](mailto:treif.china@treif.com)