

TWISTER AT

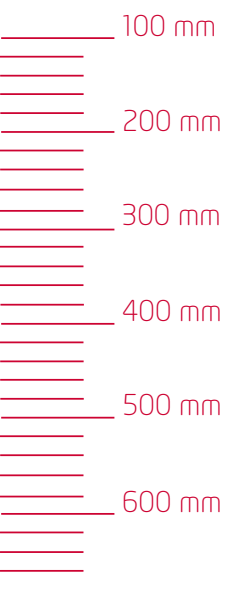

Continuously high dicing performance with fully automatic loading:
TWISTER AT

Passion for Food Cutting





Continuously high dicing performance with fully automatic loading: TWISTER AT

The operator of the TWISTER AT can expect continuously high dicing performance requiring a minimum of manpower. The machine is loaded fully automatically and achieves an hourly output of up to 3.95 tonnes/8,708 lbs (theoretical maximum value). The blade speed is variable and can be optimally adapted to the product.

The cut product is discharged according to the customer's specific requirements (e.g. 200 l standard trolley, discharge belt conveyors) or directly onto the portion scales for precisely weighed prepacked portions.



Technical data

Max. output in t/h (theoretical maximum value)	3.95; 8,708 lbs
Max. cut-off length (mm/inch)	1-50; 1/25"-2"
Max. blade speed/min.	from 100 to 400
Cutting chamber size WxH (mm/inch)	120 x 120; 4 ⁷ / ₁₀ " x 4 ⁷ / ₁₀ "
Max. infeed length (mm/inch)	620; 24 ² / ₅ "
Housing dimensions (mm/inch)	
Length with belt / with tower lift	3,076 / 3,076; 121" / 121"
Width with belt / with tower lift	2,930 / 2,278; 115 ² / ₅ " / 89 ⁷ / ₁₀ "
Height with belt / with tower lift	2,023 / 2,800; 80" / 110 ¹ / ₅ "
Connected load (kW)	7.0
Gridsets (mm/inch)	4/5/6/8/10/12/15/17/20/24/30 /40/60/120 1/5"; 3/10"; 2/5"; 1/2"; 3/5"; 7/10"; 4/5"; 1"; 1 1/5"; 1 3/5"; 4 7/10"
Weight (kg/lb)	950; 2,095
Product specific accessories / scale	on request



TWISTER AT: The high-capacity fresh meat specialist



Hopper and cutting chamber have an enormous capacity. With a loading length of 620 mm/24 ²/₅" and a loading width of 240 mm/9 ¹/₂", the cutting chamber offers ample space even for large shoulder pieces.



Excellent cutting results thanks to the patented gentle cut gridset (optional). This ensures the best possible cutting geometry for excellent cutting results, particularly with delicate products such as cooked meat or boiled sausage.



The opening distance of the cutting chamber of 240 mm/9 ¹/₂" is twice as large as the chamber proper, thus allowing maximum filling to be achieved. Two press rams ensure optimum product compression and the correct form of the cubes.

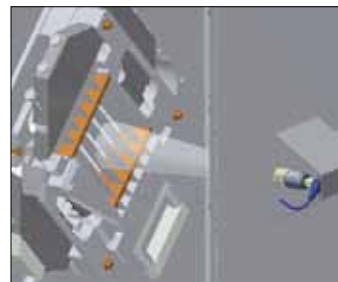

For very tender fresh meat the fresh meat kit is recommended (optional). Apart from the gentle cut gridset and the gentle cut blade, this also includes the sensor-based cutting technology (TREIF patent). The sensors regulate the frequency of the blade to achieve exactly the set cube size.



The blade speed can be set between 100 and 400 revolutions/min and thus optimally adapted to the product and the application.



For delicate products, the vartronic technology (optional) ensures even more gently cutting of the product. The cutting speed is adapted to the product – thanks to the separate drives for upper/lower gridsets and the blade.



And if you want more output, you can install the fourfold blade (optional).



The fourfold disc can be used for cutting small plates, e.g. for soups.

Precision on all 6 sides

Precisely formed cubes and strips can only be produced if there is an extremely small distance between the blade and the gridsets.

This minimum distance (the so-called "scissors' cutting principle") can only be created by applying the highest component production standards and is the reason why the individual cubes of meat are not attached to the next cube via a fibre ("goulash-chains").



The TWISTER AT has an enormous range of potential applications.

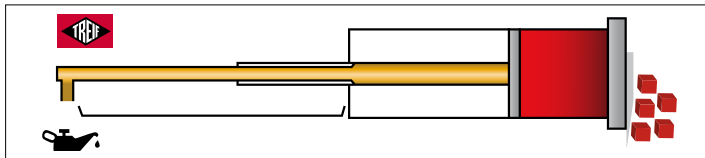

The hygiene cylinder (optional) makes product contamination with hydraulic oil technically impossible. No oil can enter the cutting chamber.

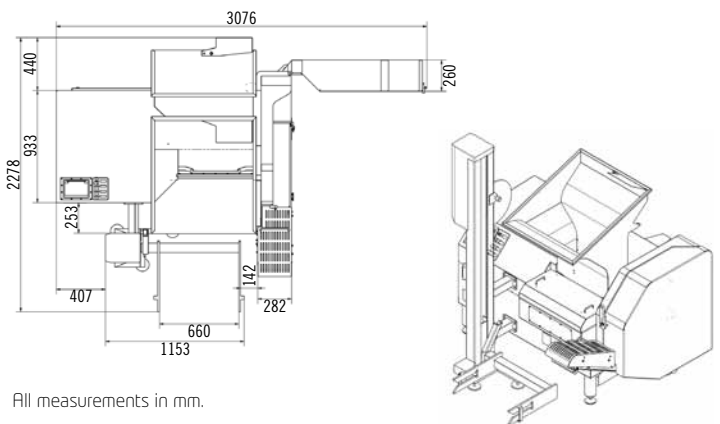
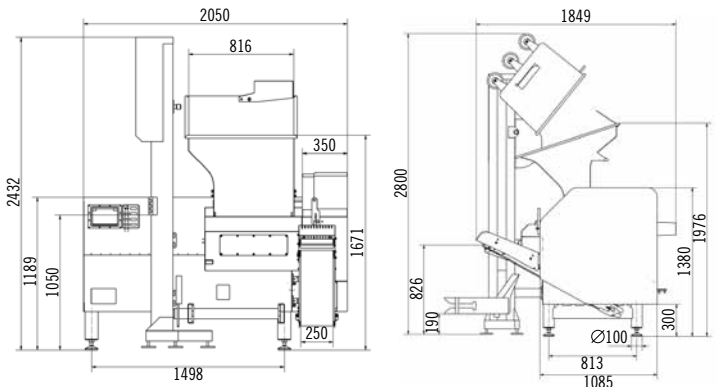

All measurements in mm.

Your benefits at a glance:

- Cost and time saving loading options: fully automatic tower lifting and tilting device for 200 l standard trolley in hopper, conveyor belt in hopper or customer-specific solutions
- Flexibility and high performance thanks to the choice between continuous and intermittent cutting and to the individually adjustable blade speed
- Optimum compression of the product and therefore efficient use of the cutting chamber capacity due to lateral compression device; additional benefit: Opening distance (240 mm / 9 1/2") twice as large as the cutting chamber (120 mm / 4 7/10")
- Reliable protection against the hydraulic oil of the feed cylinder entering the cutting chamber; hygiene cylinder (optional) makes product contamination with hydraulic oil (only foodstuff hydraulic oil is employed at TREIF) technically impossible
- Extra gentle, precise dicing of delicate products thanks to patented gentle cut gridset (optional) and vartronic technology (optional); fresh meat kit (optional) incl. sensor-based cutting technology (TREIF patent)
- Product quality assurance due to PQS (optional): Lubricants that possibly accumulate during the cutting process cannot drop into the cut product

HEADQUARTERS:

TREIF Maschinenbau GmbH
Toni-Reifenhäuser-Str. 1
D-57641 Oberlahr
Phone +49 2685 944 0
Fax +49 2685 1025
E-Mail: info@treif.com

Further LOCATIONS:

TREIF U.K. Ltd.
Genesis House, Poole Hall Road
Poole Hall Industrial Estate
Ellesmere Port, GB-Cheshire CH66 1ST
Phone: +44 (0) 151 3506100
Fax: +44 (0) 151 3506101
E-Mail: treifuk@treif.com

TREIF USA Inc.
50 Waterview Drive, Suite 130
Shelton, CT 06484
Phone: +1 203 929 9930
Fax: +1 203 929 9949
E-Mail: treifusa@treif.com

Belgium

China

France

Italy

Russia

www.treif.com